

Hydraulic Pump Instruction Sheet

PN: 2819 and 2820 Hydraulic Hand Pumps

Introduction

Thank you for purchasing a Hydraulic Hand Pump from Crystal Engineering. Hydraulic hand pumps provide a portable pressure source for calibration of high pressure gauges, recorders, switches and transmitters. The built-in variable volume provides a way to set the pressure precisely, regardless of how high the pressure is.

This instruction sheet covers both versions of the pump - the only difference is the maximum pressure rating of the pumps: 3000 or 5000 PSI (200 or 350 bar). There are two pressure ports on the pump. Mount a Digital Test Gauge or a 30 Series Pressure Calibrator directly to the front of the pump, connect the spare port directly to the device being tested, and you have a complete field pressure calibration system. A 1m (3ft.) high pressure hose, and quick test conversion fitting (1/4" NPT male to quick test) is included, along with a convenient plastic bottle for hydraulic fluid. **A rebuild kit is available**, PN: 2940, so that you can service the pump yourself, if necessary.

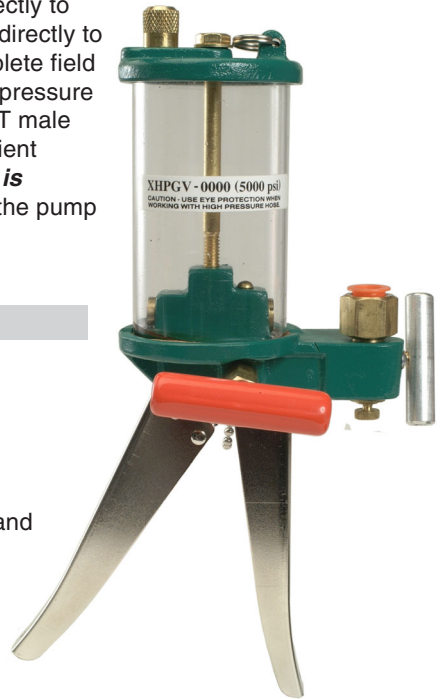

Specifications

Pressure Range:

PN: 2819 20 MPa 200 bar 3000 PSI

PN: 2820 35 MPa 350 bar 5000 PSI

Connections

One 1/4" Female National Pipe Thread (NPT) and one (female) quick test fitting.

Weight

677g (1 lb., 8 oz.)

Dimensions

Approximately 26 mm (10.5") tall

Wetted Materials

Internal parts of the pump are made of Buna-N rubber, aluminum, brass and stainless steel. The pump can be used with oil, water, or other compatible fluids. Use of water will accelerate wear of "O" rings and some sticking of piston may result. The recommended fluid is any petroleum based hydraulic oil, light weight motor oil or mineral oil. Do not use brake fluid or synthetic oils; they may crack the polycarbonate reservoir or cause swelling or decomposition of the "O" rings.

Operating Instructions

For safe and reliable operation please spend a few minutes reading the following instructions.

WARNING

To prevent damage to the pump and possible injury, never connect your pump to a pressure source greater than 35 MPa (5000 PSIG, 350 bar).

Turn off, or isolate, all pressure-generating equipment from the pressure tap prior to connecting the pump. Since handpumps are small displacement pumps, be sure to minimize the volume to be pressurized.

1. **Connections.** Your pump has two connections: A ¼" female NPT pressure port for your reference gauge (like a Digital Test Gauge or 30 Series calibrator) and a hose adapter with integral shutoff valve. Always use PTFE (polytetrafluoroethylene) tape on the threads of any pressure fittings installed into the NPT port. Connect your reference gauge, or plug the ¼" female NPT port prior to priming or using your pump. As for the hose connection, we offer a wide variety of conversion fittings to permit using the system with most commonly used fittings.
2. **Fluid.** Choose a fluid for your pump. We recommend any petroleum based hydraulic oil, lightweight motor oil, or mineral oil. Water can also be used, but it will accelerate the wear of "O" rings, and may cause some sticking of the piston. Do not use brake fluid or synthetic oils which may attack the polycarbonate reservoir, or cause swelling or decomposition of the "O" rings. Your fluid can be stored in the convenient plastic fluid dispensing bottle (supplied with the pump).
3. **Prime the pump.** Put a small amount of fluid in the reservoir. The easiest way to fill the reservoir is to remove the vent plug, and use the fluid bottle to squirt fluid into the reservoir. Open the bleed-off valve (the red, plastic coated handle opposite the hose connection) by turning it counter-clockwise, then squeeze the handle. Fluid should circulate out the bleed-off valve hole back into the reservoir. Then fill the reservoir, in preparation for use. We recommend that you keep the pump primed.
4. **Operation.** Shut-off the (red) bleed-off valve. Remove the cap covering the brass adaptor on side of the pump, and connect your hose. As the hose is connected to the adaptor it opens a small check valve in the adaptor. We suggest that you squeeze the pump handle to fill the hose with fluid, prior to connecting the other end of the hose to the instrument to be calibrated. This minimizes the volume of air you will need to compress to achieve your desired pressure. In fact, the less air you have in your system, the better the pump will perform.

To establish a zero pressure reference, have the pump at the same elevation as the device being tested, and open the (red) bleed-off valve. Close the valve, and repeatedly squeeze the handle until you are close to, but not greater than, your desired pressure point. Then use the the variable volume handle to adjust the pressure to precisely your desired pressure. The pressure may initially appear to be unstable, and dropping. This is usually due to either a small amount of expansion of the hose under pressure, and/or residual air or gas dissolving into the hydraulic fluid. If there are no leaks, both of these effects will diminish until

the pressure is stable. Of course, very high resolution pressure calibrators will detect this effect better than low cost mechanical gauges.

- 5. Troubleshooting - if the pump will not pump.** The pump has probably lost its prime. If it will not prime, remove the reservoir and insert a small wire into the inlet check valve hole to make sure the valve moves freely. Squirt oil into the inlet check valve while squeezing and releasing the handle. Then reinstall the reservoir and prime the pump. Another possible reason for pump failure is dirt under one of the check valves may prevent fluid from flowing freely back into the reservoir. We recommend removing, cleaning and reinstalling the check valves.
- 6. Troubleshooting - if the pump does not hold pressure.** The pump may be leaking internally or externally. If pressure goes up when the handle is squeezed and drops when the handle is released, the dirt is under the outlet check valve. Remove the brass plug, clean the check valve and reinstall.

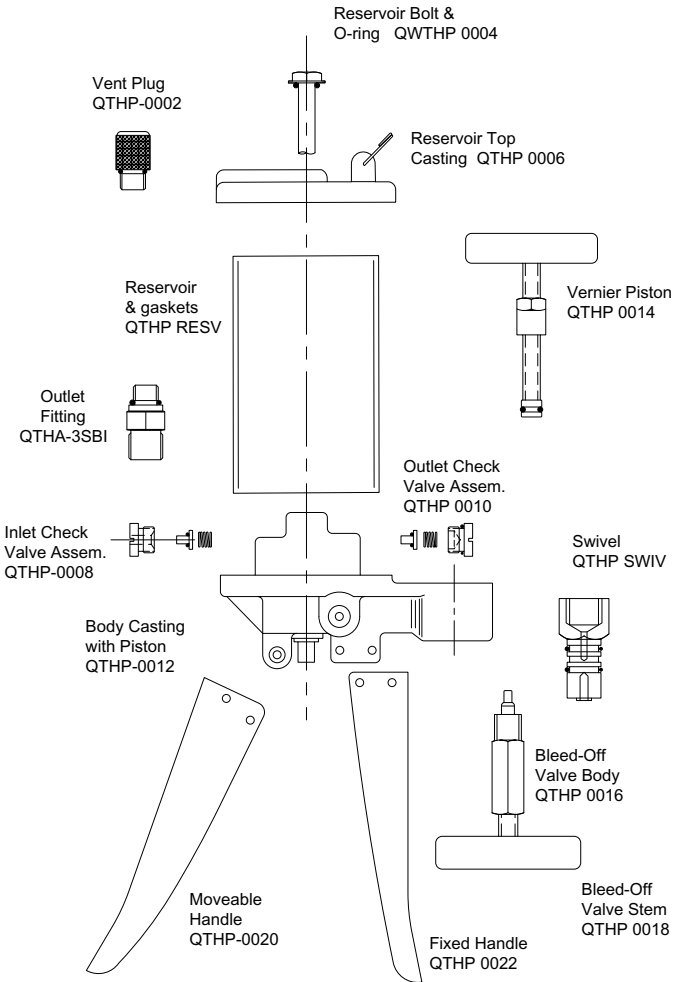

Warranty

Crystal Engineering Corporation warrants the Hydraulic Pump to be free from defects in material and workmanship under normal use and service for one (1) year from date of purchase to the original purchaser. It does not apply when the product has been misused, altered or damaged by accident or abnormal conditions of operation.

For in (or out) of warranty service, we can be reached at:

Phone (805) 595-5477

Toll-Free (800) 444-1850

Fax (805) 595-5466

Email service@crystalengineering.net

Web www.crystalengineering.net

If calling, have ready the model number, serial number, date of purchase and reason for return. You will receive instructions for returning the device to Crystal Engineering.

Crystal Engineering will, at our option, repair or replace the defective device free of charge and the device will be returned, transportation prepaid. However, if we determine the failure was caused by misuse, alteration, accident or abnormal condition of operation, you will be billed for the repair.

CRYSTAL ENGINEERING CORPORATION MAKES NO WARRANTY OTHER THAN THE LIMITED WARRANTY STATED ABOVE. ALL WARRANTIES, INCLUDING IMPLIED WARRANTIES OF MERCHANTABILITY OR FITNESS FOR ANY PARTICULAR PURPOSE, ARE LIMITED TO A PERIOD OF ONE (1) YEAR FROM THE DATE OF PURCHASE. CRYSTAL ENGINEERING SHALL NOT BE LIABLE FOR ANY SPECIAL, INCIDENTAL OR CONSEQUENTIAL DAMAGES, WHETHER IN CONTRACT, TORT OR OTHERWISE.

Note (USA only): Some states do not allow limitations of implied warranties or the exclusion of incidental or consequential damages, so the above limitations or exclusions may not apply to you. This warranty gives you specific legal rights and you may have other rights which vary from state to state.

© 2002, Crystal Engineering Corporation

720 Aerovista Place, Suite B

San Luis Obispo, CA 93401-8701